



PERFORMANCE YOU CAN COUNT ON:
UBC RECYCLING EQUIPMENT FROM CP MANUFACTURING



CP MANUFACTURING INTRODUCED THE WORLD'S FIRST ALUMINUM CAN FLATTENER... TRUST THE LEADER

CD3600 CAN DENSOR

- ✓ FREE UP YOUR BALER
- ✓ REDUCE LABOR COSTS
- ✓ SHIP AT MAXIMUM WEIGHT

For high volume users- it's got superior quality and outstanding dependability. It has a unique ram design that provides for longer ram life and easier maintenance.

The CD3600 processes up to 3,600 lbs. of aluminum cans per hour into 7"x13"x20" biscuits. These 40 lb. biscuits require fewer machine cycles and minimum handling; that gives you the highest profit for your investment.

Designed to be fast and fully automatic, eliminating the need for constant attendance, it can be fed from different directions to fit confined work areas. And its low noise level makes it ideal for indoor use.

The main ram rod is enclosed and protected from the dirt, debris and moisture common during can processing. That means you get a longer machine life, with lower maintenance requirements than ever!

FEATURES:

- Unique main ram design that protects the ram from dirt, debris & moisture
- Designed to be a dependable production machine for high volume users
- Processes up to 2,400 lbs/hour of unflattened cans or up to 3,600 lbs. per hour of pre-flattened cans
- Fully automatic cycle eliminates the need for constant attendance
- All machine functions are operated by solid state programmable controllers
- Lower maintenance, less service time, & extended machine life due to:
 - Thermostatically controlled hydraulic oil cooler
 - 40 lb. 7"x13"x20" biscuits require fewer machine cycles to produce & require minimum handling
 - Rugged, reliable construction including 3" steel plates
- Can be fed from different directions to fit any location
- Replaceable bolt-in platen & bale chamber wear liners

BISCUIT DENSITY:

- 38-42 lbs./cubic foot

SPECIFICATIONS:

- 25 HP power unit
- 460 volt 3 phase wiring
- Solid state programmable controller
- Thermostatically controlled hydraulic oil cooler
- 1 cubic yard hopper
- 120 gallon hydraulic tank
- 20-1/2" wide infeed conveyor with 3/4 HP motor, direct drive gear reducer, magnetic head pulley and steel reject chute

OPTIONS:

- 208, 230, 380, 415 or 575 volt 3 phase wiring
- Oil heater
- Larger hoppers

DIMENSIONS:

- Height—9'2"
- Width—3'10"
- Length—13'5"
- Machine weight—8,000 lbs.
- Conveyor weight—1,000 lbs.
- Conveyor: 11'5" high x 20-1/2" wide x 13' long

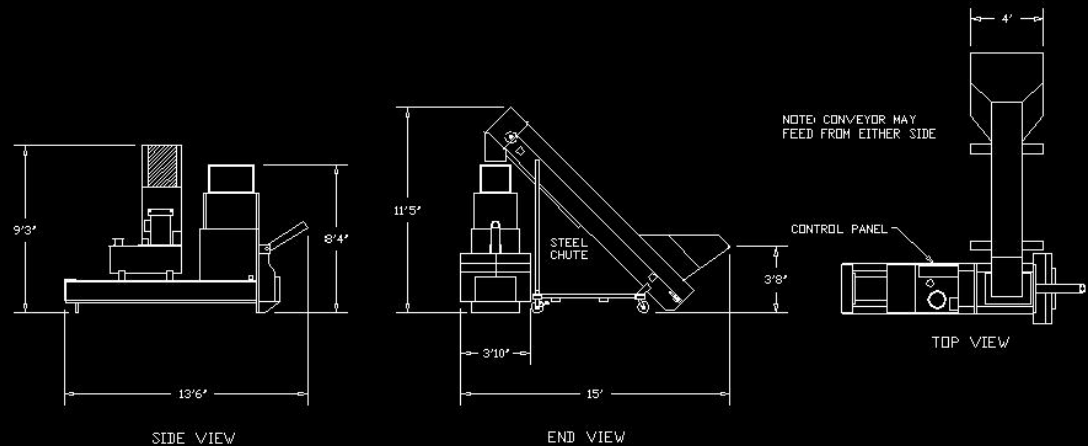
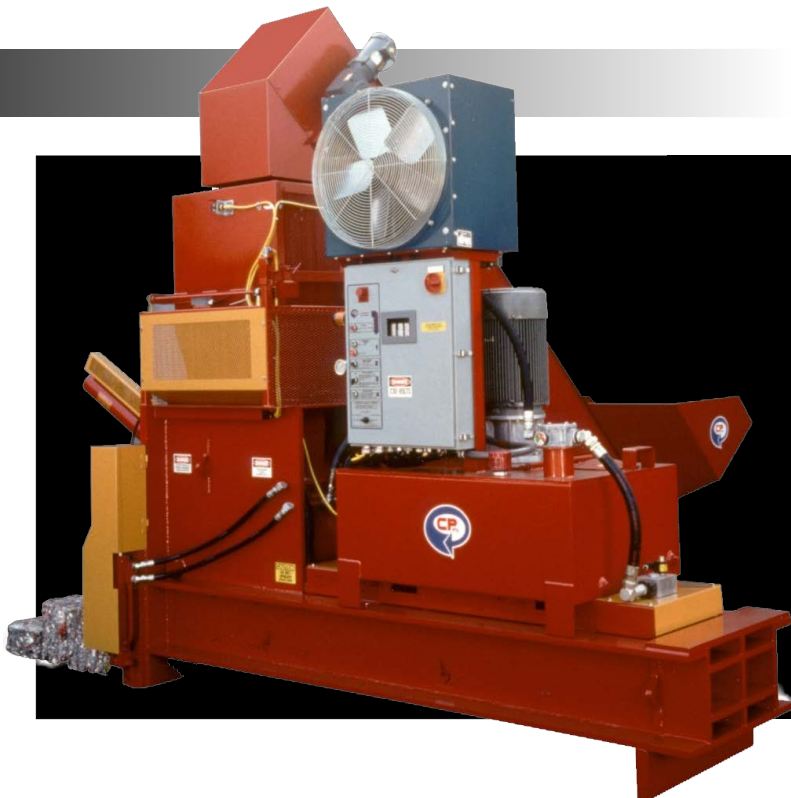

CD1200 CAN DENSOR

✓ STATE-OF-THE-ART CONTROLS

✓ FULLY AUTOMATIC

The CD1200 is amazingly quiet and remarkably compact, yet the volume it produces is BIG. It separates and densifies 800 to 2000 lbs. of aluminum cans per hour into 18 lb. biscuits. It does this while automatically adjusting to accept whole or flattened cans to give you maximum throughput.

The uniformly sized biscuits stack and band easily, without pallets, into manageable 2500 lb. bundles. That allows you the flexibility of shipping only one bundle to improve your cash flow, or you can ship maximum loads for the best price per pound. Plus, the CD1200 is entirely automatic, eliminating the need for constant attendance.

CP Mfg. has always delivered rugged, durable equipment. With the CD1200, it starts with an innovative, streamlined design that has fewer moving parts to give you longer machine life. Hinged doors, removable panels and bolted-in, removable bale chamber liners make routine service simple & inexpensive. All moving parts are totally enclosed for safety.

FEATURES:

- Processes from 800 to 2000 lbs. per hour of aluminum cans
- Densifies steel beverage containers as well as aluminum cans
- Automatically adjusts for whole or mixed cans to give the maximum pounds per hour throughput
- Fully automatic cycle eliminates the need for constant attendance
- All machine functions are operated by a solid state programmable controller inside a re-designed Control Panel featuring Siemens Automation control components
- All moving parts are fully enclosed for maximum operation safety
- Biscuit eject guard

BISCUIT DENSITY & CAPACITY:

- 38-42 lbs./cubic foot
- Self-adjusting from 800 to 2000 lbs. per hour of aluminum cans, depending on the density of the cans being processed

SPECIFICATIONS:

- Horsepower limiting hydraulic pump
- Solid state programmable controller
- 230 volt or 460 volt 3 phase wiring
- 20 HP power unit
- 1 cubic yard hopper
- Thermostatically controlled hydraulic oil cooler

OPTIONS:

- 208, 380, 415 or 575 volt 3 phase wiring
- Oil heater
- Larger hoppers

DIMENSIONS:

- Height—7'
- Width—2'
- Length—10'2"
- Machine Weight—3,500 lbs. (without conveyor)
- Biscuit dimensions: 6"x10"x13"
- Average biscuit weight—18 lbs.
- Average bundle weight—2500 lbs.

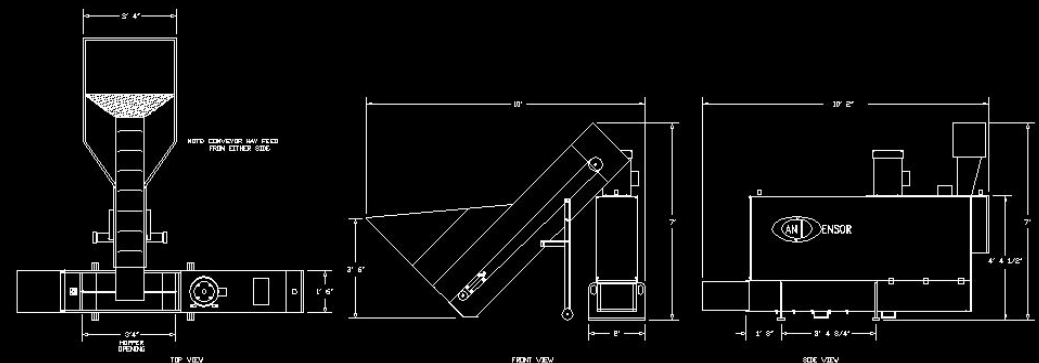

CD600 CAN DENSOR

- ✓ VERY LOW MAINTENANCE
- ✓ LONG MACHINE LIFE
- ✓ SAFE OPERATION

Successful recycling is efficient recycling. There's simply no more efficient way to handle aluminum cans than to densify them. The CD600 separates and densifies 500 to 1000 lbs. of aluminum cans per hour into 18 lb. biscuits. These uniformly sized biscuits stack and band easily without pallets into 2500 lb. bundles for easy handling. Densifying allows you to ship maximum weight loads- meaning you'll never pay to ship air again.

The CD600 is unusually quiet and remarkably compact. It's entirely automatic, eliminating the need for constant attendance while automatically adjusting to accept whole or flattened cans.

With fewer moving parts and the elimination of pre-weighing, the CD600 gives you the lowest maintenance possible. Bolted-in, removable bale chamber liners, solid state programmable controller and photoelectric sensors all combine to provide a longer machine life and virtually eliminate maintenance. Hinged doors, removable panels and a modular controller add up to easy, low cost servicing. And all moving parts on the CD600 are totally enclosed for safety.

FEATURES:

- Processes from 500 to 1000 lbs. per hour of aluminum cans
- Automatically adjusts for whole or mixed cans to give the maximum pounds per hour throughput
- Fully automatic cycle eliminates the need for constant attendance
- All machine functions are operated by solid state, programmable controllers
- Ideal densifier for indoor use due to low noise level, compact size and attractive design
- Minimum number of moving parts—fully enclosed for maximum operational safety
- Removable bale chamber liners
- Rugged construction and innovative design
- Biscuit eject guard

BISCUIT DENSITY & CAPACITY:

- 38-42 lbs./cubic foot
- Self-adjusting from 500 to 1000 lbs. per hour of aluminum cans, depending on the density of the cans being processed

SPECIFICATIONS:

- Horsepower limiting hydraulic pump
- Solid state programmable controller
- 230 volt or 460 volt 3 phase wiring
- 10 HP power unit
- Thermostatically controlled hydraulic oil cooler

OPTIONS:

- 208, 380, 415 or 575 volt 3 phase wiring
- Oil heater
- Spare parts kit

DIMENSIONS:

- Height—7'
- Width—2'
- Length—10'2"
- Machine weight—3,000 lbs. (without conveyor)
- Average biscuit weight—18 lbs.
- Average bundle weight—2500 lbs.
- Biscuit dimensions: 6"x10"x13"

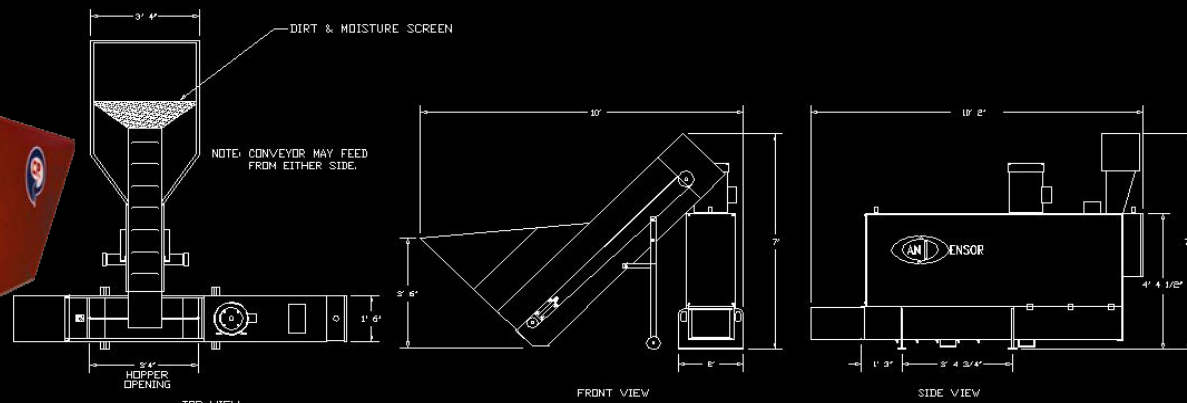

CP250 CAN FLATTENER/BLOWER

✓ LOW MAINTENANCE

✓ EXTREMELY DURABLE

It's compact, yet extremely powerful. It's easy to maintain and built to last. It's the CP250 Can Flattener/Blower from CP Manufacturing.

The CP250 flattens up to 2700 lbs. of aluminum cans per hour. A conveyor with a magnetic head pulley lets you visually inspect the cans while it rejects most steel contaminants. A 7.5 HP blower, combined with the delivery tube's swivel base and adjustable head, allows you to easily fill up to a 45 ft. trailer with maximum efficiency.

The CP250 is an advanced state-of-the-art can flattener. It's a fourth generation machine that's been field proven to have low maintenance requirements. That means you get the high production you need—and the extended machine life you want.

If you are looking for lasting, dependable quality, you'll find it designed right into the CP250 Can Flattener/Blower. Special features like a reversible drum with wear resistant, replaceable drum cleats, and swing plate lower liner provide added durability and allow for simple rapid servicing.

FEATURES:

- Designed as a dependable, high volume machine with extended life
- Field proven, fourth generation CP flattener
- Processes up to 2700 lbs. of cans per hour
- Lower maintenance life due to:
 - Heavy duty, reliable construction
 - Reversible drum with wear resistant, replaceable drum cleats
- High volume blower and adjustable, large capacity delivery tube let you easily fill up a 45 ft. trailer
- Compact size
- Safety limit switch

DENSITY & CAPACITY:

- Up to 2700 lbs. per hour of aluminum cans
- 7-8 lbs. per cubic foot

SPECIFICATIONS:

- 7-1/2 HP Flattener Motor
- 7-1/2 HP Blower Motor
- 1/3 HP Conveyor Motor
- 230 volt 3 phase or 460 volt 3 phase wiring
- 10" diameter, 12' long delivery tube
- Magnetic head pulley and steel reject chute
- 17" wide, cleated conveyor belt
- 3/4 Cubic yard hopper
- Mounted on 8" casters for mobility
- Dirt and moisture screen

OPTIONS:

- Optional voltages available including 230 volt Single phase

DIMENSIONS:

- Height—6'
- Width—3'6"
- Length—12'
- Weight—2,200 lbs.

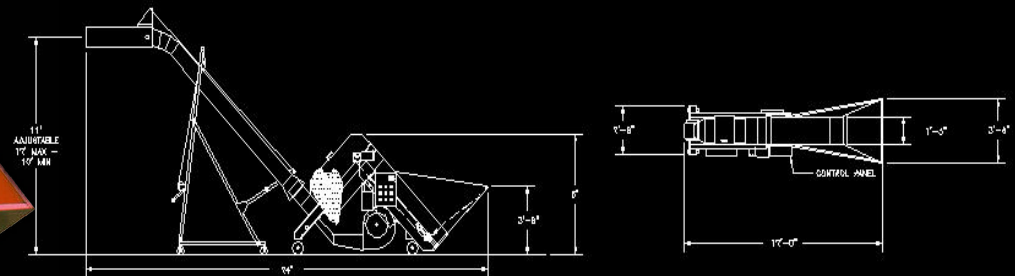
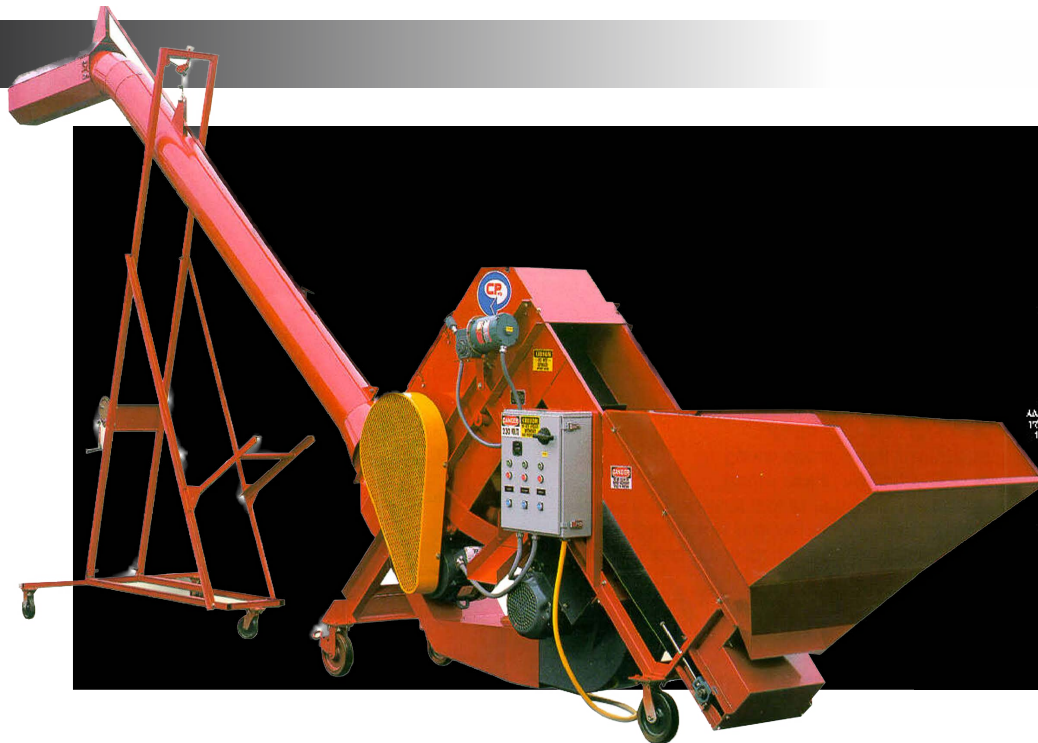

CC1207 CAN SORTER



QUICKLY SEPARATES FERROUS FROM NON-FERROUS



DURABLE DESIGN

Making the most of your valuable time and resources by buying only what you can resell is important. And that's what the CC1207 Can Sorter from CP Manufacturing is all about. It allows you to easily sort aluminum cans from steel and other contaminants before you buy them, making your recycling more efficient and more profitable.

The CC1207 sorts up to 2500 lbs. of aluminum cans per hour. It quickly and efficiently separates steel from aluminum. Simply dump the cans into the hopper. A 12" wide conveyor belt with vulcanized PVC cleats carries a single layer of cans over a magnetic head pulley, efficiently removing steel cans and other ferrous materials. The remaining aluminum cans fall into a container below. The tail pulley assembly is adjustable from outside, so you can easily adjust the conveyor belt tension.

The CC1207 is built to last. It's got a minimum of moving parts for the lowest maintenance possible. Sturdy 5" casters give you flexible placement and operation. And with a strong 1/3 HP motor, you can count on this durable machine to keep on working—day-in and day-out.

FEATURES:

- Sorts up to 2500 lbs. of aluminum cans per hour
- Lower maintenance and service time due to fewer moving parts and durable construction
- Direct drive speed reducer eliminates belts and pulleys
- PVC belting with vulcanized PVC cleats
- Telescoping tail pulley assembly allows easy outside adjustment of conveyor belt tension
- Expanded metal screen in bottom of hopper helps eliminate dirt, debris and moisture
- Casters make the CC1207 easy to move
- Rugged construction and innovative design
- Efficient, compact design

SPECIFICATIONS:

- All steel construction
- 1/3 HP Drive motor
- 5" Casters
- 6" Diameter permanent magnetic head pulley
- 12" PVC conveyor belt with vulcanized PVC cleats
- 3/4 Cubic yard hopper
- Thermal rated start/stop switch
- Direct drive speed reducer
- Expanded metal dirt screen
- 115 volt single phase

OPTIONS:

- 230 volt Single phase
- 230, 380, 415, 460 or 575 volt three phase wiring

DIMENSIONS:

- Height—6'10"
- Length—9'2"
- Conveyor width—12"
- Hopper width—3'4"
- Weight—500 lbs.



SIDE VIEW

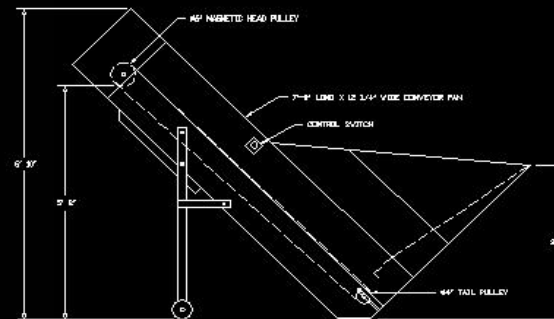

TOP VIEW

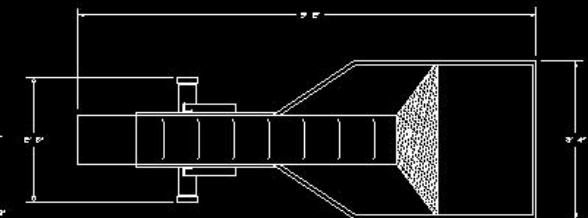

CC2013 CAN SORTER

✓ COMPACT DESIGN

✓ QUICKLY SEPARATES FERROUS FROM NON-FERROUS

Making the most of your valuable time and resources by buying only what you can resell is important. And that's what the CC2013 Can Sorter from CP Manufacturing is all about. It allows you to easily sort aluminum cans from steel and other contaminants before you buy them, making your recycling more efficient and more profitable.

The CC2013 sorts up to 6000 lbs. of aluminum cans per hour. It quickly and efficiently separates steel from aluminum. Simply dump the cans into the hopper. A 20" wide conveyor belt with vulcanized PVC cleats carries a single layer of cans over a magnetic head pulley, efficiently removing steel cans and other ferrous materials. The remaining aluminum cans fall into a container below. The tail pulley assembly is adjustable from outside, so you can easily adjust the conveyor belt tension.

The CC2013 is built to last. It has minimal moving parts for the lowest maintenance possible. Sturdy 8" casters give you flexible placement and operation. And with a strong 3/4 HP motor, you can count on this durable machine to keep on working—day-in and day-out.

FEATURES:

- Sorts up to 6000 lbs. of aluminum cans per hour
- Lower maintenance and service time due to fewer moving parts and durable construction
- Direct drive speed reducer eliminates belts and pulleys
- PVC belting with vulcanized PVC cleats
- Telescoping tail pulley assembly allows easy outside adjustment of conveyor belt tension
- Expanded metal screen in bottom of hopper helps eliminate dirt, debris and moisture
- 8" Casters make the CC2013 easy to move
- Efficient, compact design

SPECIFICATIONS:

- All steel construction
- 1/3 HP Drive motor
- 8" Casters
- 8" Diameter permanent magnetic head pulley
- 20" wide PVC conveyor belt with vulcanized PVC cleats
- 3/4 Cubic yard hopper
- Thermal rated start/stop switch
- Direct drive speed reducer
- Expanded metal dirt screen
- 230 volt 3 phase

OPTIONS:

- 230 volt Single phase
- 380, 415, 460 or 575 volt three phase wiring

DIMENSIONS:

- Height—11'5"
- Length—15'2"
- Conveyor width—20"
- Hopper width—3'4"
- Weight—800 lbs.

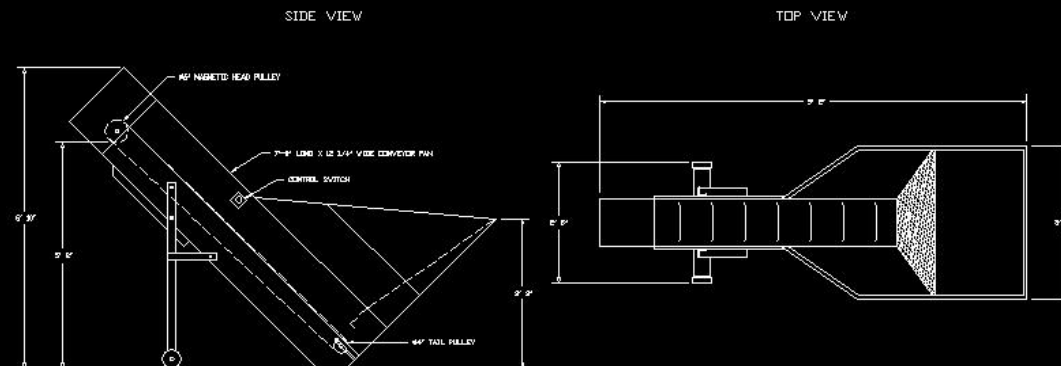

GC100 GLASS CRUSHER

✓ CRUSHES 7,000 LBS GLASS/HR

✓ DURABLE DESIGN

It's rugged, durable and built to last. It's efficient and gets the job done, day-in and day-out. It's the GC100 Glass Crusher from CP Manufacturing—the company that sets the pace for the industry's UBC processing equipment.

The GC100 crushes up to 7000 pounds of glass per hour. A tough, PVC cleated belt carries the glass up the conveyor, allowing for visual inspection before it enters the crushing chamber. It efficiently handles up to a 4-liter container, breaking it into approximate 1-inch pieces of recyclable cullet. And that lets you reduce your volume, easily fill your shipping containers—and ship maximum weight truckloads to reduce your freight costs.

The GC100 works, and keeps on working. It features cast chromium alloy steel crusher bars that are extremely resilient. It has a completely replaceable crushing drum liner. It's constructed of durable, heavy gauge steel. And all you need is 115 volt Single phase power.

FEATURES:

- Heavy gauge steel construction
- Cast chromium steel crusher bars (4 crusher bars included)
- Replaceable crushing drum liner
- Removable catch tray
- Fork lift slots
- Shaft mounted conveyor speed reducer

CAPACITY:

- Up to 7000 lbs. / hour
- Up to 600 cases/hour

SPECIFICATIONS:

- 4'2" discharge height
- 115 volt single phase wiring
- 1/3 cubic yard hopper
- Mounted on 8" casters
- 1/2 HP crusher motor
- 1/2 HP conveyor motor
- 15' wide, PVC cleated conveyor belt
- Conveyor belt speed: 55 FPM

OPTIONS:

- 230 volt Single phase
- 380, 415, 460 or 575 volt three phase wiring

DIMENSIONS:

- Height—8'
- Length—13'9"
- Width—4'
- Conveyor belt width: 15"
- Hopper width—36"
- Weight—1000 lbs.



BUILT TO PERFORM. BUILT TO LAST.

All CP equipment is designed, built, and field-proven to meet your demands and requirements and is completely production-tested in our plant before it is shipped to you!

CP Manufacturing introduced the world to automated aluminum can recycling in the early 70's. Today, with more than 10,000 pieces of our ultra-efficient, low-maintenance separating and processing equipment in operation, we continue to lead the industry in anticipating and meeting its needs. CP recycling equipment is built to last.

Whatever your processing volume, whatever your needs, CP has the dependable, low-maintenance equipment you need for high throughput and quality end-products.

CP products are engineered and built in our own plant and field-tested in our own recycling centers and MRF. We've manufactured the majority of used beverage container recycling equipment in the world. We know what it takes to get the job done right.

Contact us:

Tel: 619.477.3175

Fax: 619.477.3426

Toll Free: 1.800.462.5311

www.CPmfg.com

Email: JudyC@CPmfg.com

CP Manufacturing, Inc.
6795 Calle de Linea
San Diego, CA 92154



The CP Group: Your Single Source Solutions Partner

The CP Group of Companies is comprised of 5 industry-proven brands that unified to provide the waste and recycling industry a single source solution for Material Recovery Facilities and equipment. With over 155 years of combined company experience, the CP Group has grown with the industry as a pioneer and leader of recycling equipment and innovation.

We are unique among equipment vendors in that we own a MRF in San Diego, CA, used as a Research & Development facility where we put our new innovations to test. Being an operator of this 20 TPH single stream facility gives us key insight into our customers perspective. We also own and operate numerous pieces of our own can densor equipment in our scrap yard. We understand what it takes to run a successful operation, from our customer's perspective.

Material Recovery Facilities:

- Single Stream Recycling
- Municipal Solid Waste (MSW)
- Engineered Fuel (WtE)
- Construction & Demolition (C&D)
- Commercial & Industrial (C&I)
- eWaste and more

Recycling Equipment:

- Can Densors/Flatteners
- Balers
- Conveyors
- Disc Screens
- Trommel Screens
- Optical Sorters
- Intelligent Controls
- Air Classification

Company Focus:

- Long-term customer success
- Continuous innovation (R&D)
- Equipment safety
- Ethical business
- Global expansion
- Delivering expectations





CP MANUFACTURING INC.



(OFFICE) 619.477.3175
(TOLL FREE) 1.800.462.5311
6795 CALLE DE LINEA
SAN DIEGO, CA 92154
CPMFG.COM

KRAUSE MANUFACTURING INC.



(OFFICE) 360.398.7533
(TOLL FREE) 800.381.5101
316 McLEOD RD. STE. 1
BELLINGHAM, WA 98226
KRAUSEMANUFACTURING.COM

MSS INC.



(OFFICE) 615.781.2669
3738 KEYSTONE AVE
NASHVILLE, TN 37211
MAGSEP.COM

IPS BALERS INC.



(OFFICE) 912.336.9460
396 FROST INDUSTRIAL BLVD
BAXLEY, GA 31515
IPSBALERS.COM

ADVANCED MRF INC.



(OFFICE) 619.791.2420
1533 WILSON AVE
NATIONAL CITY, CA 91950
ADVANCEDMRF.COM

CPME



(OFFICE)+44(0)1706 756560
UNIT 6A, GREENVALE BUSINESS PARK
TODMORDEN ROAD
LITTLEBOROUGH, OL15 9FG, UK
CPME.CO.UK



(OFFICE) 619.477.3175
(TOLL FREE) 1.800.462.5311
6795 CALLE DE LINEA
SAN DIEGO, CA 92154



AMERICAN MANUFACTURING & ENGINEERING
© CP MANUFACTURING, INC 2014
PRINTED ON RECYCLED PAPER

theCPgrp.com